

# Curved blade cuts tunnel arch

An Italian company has designed a machine mounted with a specially made 1500 mm diameter concave diamond sawblade which is capable of forming a perfect curved cut in tunnel archways. This method has been used successfully to create safety alcoves in two road tunnels in northern Italy.

Recent changes in Italian safety laws for motorway tunnels included the provision of alcoves within the tunnels to provide a refuge for drivers and passengers. On the stretch of the A32 from Turin to Bardonecchia, this work was the responsibility of SITAF, the authority in charge of the maintenance of motorway tunnels in the area of Frejus.

Two tunnels at Cels and Prapontin were constructed with concrete arches, 5 m in diameter and between 500 and 700 mm in thickness. These had to have nearly 100 alcoves built, with the work being carried out by concrete sawing of an opening in the tunnel arch and then forming the completed alcove within this working envelope (Fig 1). The concrete cutting work was subcontracted to local company Tondin srl.

The main restraint in carrying out the work was the need to keep one of the two traffic lanes open at all times. This ruled out conventional polygonal cuts to form the arch, because this would require propping of the structure which would infringe on the roadway. It would also cause problems in terms of the time needed to complete the work

Cutting with diamond wire using a pantograph would have been ideal, but this was also ruled out, because it was a 'blind' cut and there was no way of threading the wire through the concrete.

Taking inspiration from the way that Italian marble workers obtain a round cut in plane surface by using a small concave diamond blade with a manual machine, Tondin decided to produce a much bigger machine with a bigger blade that enables a cut to be made which follows a curved line on an



arched surface with a diameter of 5 m to a depth of 650 mm (Fig 2). The two main difficulties the company faced were that the surface to be cut was not plane like a slab, but was curved, and that in order to cut 650 mm deep a blade of 1500 mm diameter with a concave shape was required.

The movement of the machine and the shape of the blade had to be designed to obtain a cut that had to be horizontal in the upper part of the arch and perpendicular to the tangent of the tunnel surface further down. To make a machine with the proper movement and a blade with that shape was considered to be impossible, so it was

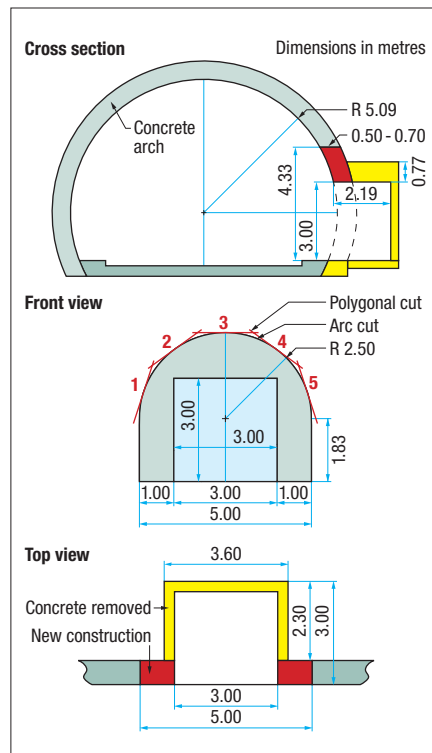

Fig 1 (above) Schematic showing details of cut areas and new construction

Fig 2 (top) Completed cut on tunnel wall

Fig 3 (left) The specially made concave diamond sawblades used for the cutting

agreed that a cutting tolerance of between 50 and 70 mm was acceptable. on this basis, Tondin set about designing the machine and sawblade.

One requirement was that the arm of the machine must be capable of achieving a cut with both a larger and smaller radius so that it could be used in other construction works where tunnel arch radii would be different. Also, particular attention had to be paid to designing the mechanism which would move the blade because with a so big radius is had to be regular in operation when going up as well as coming down. The weight of the head, the blade and the arm itself all combined to create an acceleration when coming down but would be neutral when cutting the upper part of the arch.

Tondin realised that there was no company around that was producing concave sawblades of the 1500 mm diameter size required for this job, so it decided to manufacture the blades itself.

In the end, the company produced two types of sawblade blank, one 1000 mm diameter for pre-cutting and one 1500 mm diameter to complete the full 650 mm depth. To obtain the required side run out of 0.2 mm for the 1000 mm blade and 0.6 mm for the 1500 mm blade, together with achieving the proper concave shape was very difficult. The blanks were 4 mm thick for both sizes and the steel used was not that used for conventional blanks but of a specification suitable for forming the special concave shape required.

Italian diamond toolmaker, Diamant-D SpA. supplied the segments at very short notice. Segment length was 20 mm and height 8 mm for both blades, with the thickness being 6.5 mm for the smaller blade and 6.0 mm for the larger one (Fig 3). A sandwich type design was used in both segments using 40/50 US mesh high quality diamond grit. This gave good cutting results from the start, but was modified slightly for the first re-tip to achieve even better results.

To maintain a constant depth of cut, the cutting head had to be constantly monitored as it followed the curved surface of the tunnel. Also, with the road being open to traffic during the work (Fig 4), safety was an important factor and only authorised people were allowed within the working zone.

At a power of 15 to 20 kW (Fig 5), the machine achieved a cutting rate of 0.8 to 1.5 m<sup>2</sup>/hr. Peripheral speed was between 40 and 45 m/s.

To facilitate final removal of the concrete into more manageable blocks, two vertical and two horizontal cuts were



made. Depending on the quality of the reinforced concrete, a two-man working team took between 1 to 1½ days to finish cutting out each alcove.

With repetitive work such as this in relatively dangerous working conditions, the use of specially-made machines and tools such as these enabled the project to be completed in the minimum of time and therefore with the maximum of safety. To date, 75 alcoves have been cut out and the method can be used on other tunnel arches as well as on plane concrete surfaces. In addition to the normal benefits obtained with diamond cutting (precise cuts, minimum structural damage, speed of work, reduced vibration and noise, etc) this method also produces an arched vault that in many cases can be self-supporting. ♦

**Fig 4 (above) Concrete being jack-hammered away to form the alcove**

**Fig 5 (top) Concave shaped diamond sawblade cut a circle of radius of 5 m through a thickness of 500 - 700 mm of concrete arched tunnel**

Contact:  
**Tondin Srl**, Via A. De Gasperi,  
35010 Gazzo (PD), Italy.  
Tel: +39 049 9425771  
Fax: +39 049 9425752  
tondin@tiscali.net.it

**Diamant-D SpA**, Via Palladio 40,  
35010 San Giorgio in Bosco (PD), Italy.  
Tel: +39 049 5996755  
Fax: +39 049 5996401  
email: info@diamant-d.com